



TECNOFLUID
ENGINEERING



COMPACT HYDRAULIC CYLINDERS
CC TYPE

The short-stroke cylinders of the CC series complete the wide range of special cylinders manufactured by our company for a variety of industrial sectors.

The CC short-stroke hydraulic cylinders can meet the need for small-sized presses.

The main feature of these cylinders is their reduced overall dimensions, compared with ISO cylinders, and therefore can be used to lock or move in very small spaces.

They are manufactured in the double-acting version, with magnetic sensors. Their body is provided with holes for sensors.

All CC short-stroke cylinders are equipped with a magnetic piston with two PTFE anti-friction shoes for a precise guide and reduced friction.

Cylinders can be clamped by means of the holes available on their body.

The CC short-stroke hydraulic cylinders by Tecnofluid meet the strictest reliability requirements, also under heavy duty, whenever precise pushes and considerable work loads are required.

Technical characteristics:

Bore: 20÷100mm

Standard stroke: 20 and 50 mm

Rated pressure: 160 bar

Maximum pressure: 250 bar

Fluid temperature: -20 ÷ +80°C (standard gaskets)

Fluid temperature: -20 ÷ +150°C (Viton gaskets)

Recommended fluid: Mineral Hydraulic oil / phosphoric esters

Coding key:

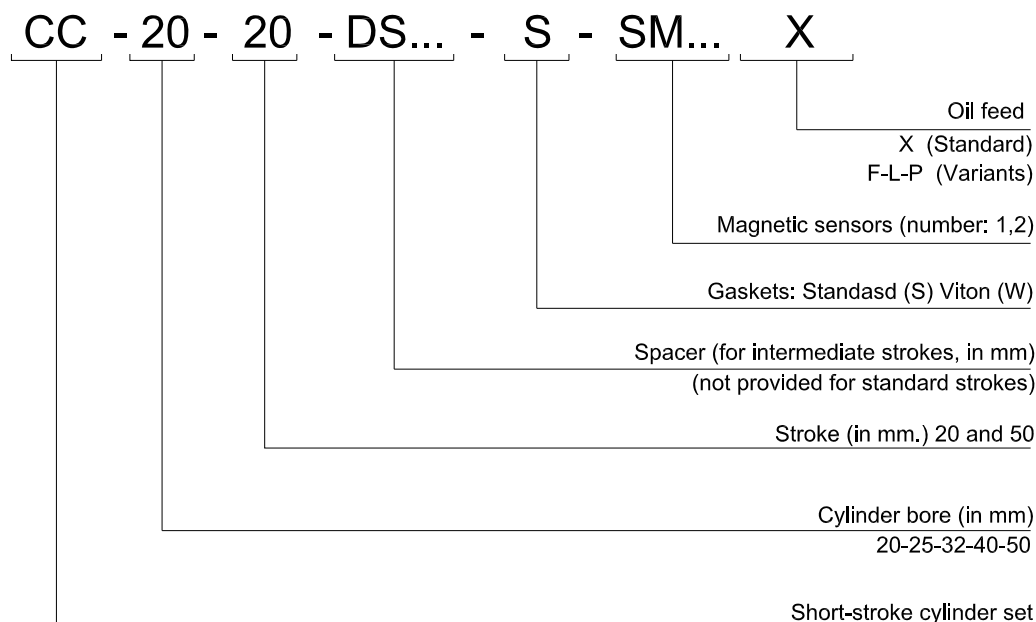

STRUCTURAL CHARACTERISTICS

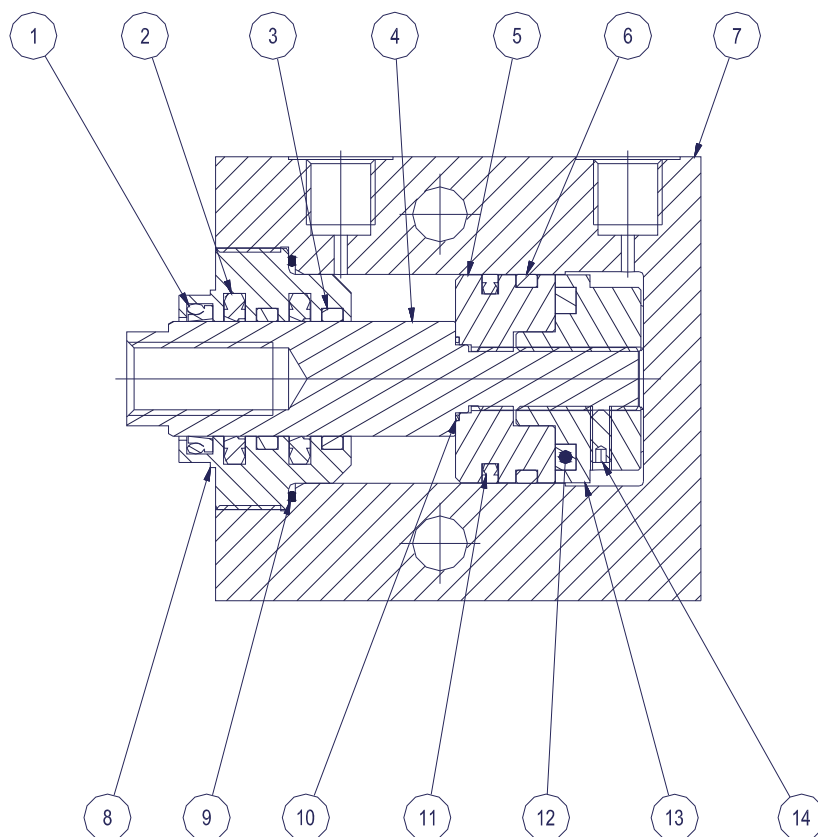

Ref.	Components	Material	Ref.	Components	Material
1	Dust scraper	Nitrile rubber + PTFE	8	Guide bushing	Steel
2	Stem gasket	NBR/fiber	9	O-ring	Nitrile rubber
3	Anti-friction shoe	PTFE	10	O-ring	Nitrile rubber
4	Stem	Chromium-plated steel	11	Piston gasket	Nitrile rubber + PTFE
5	Piston	Steel	12	Magnet	Neodymium
6	Anti-friction shoe	PTFE	14	Screw	Steel
7	Body	Special light alloy	15	Anchor plate	Steel

BASIC VERSION

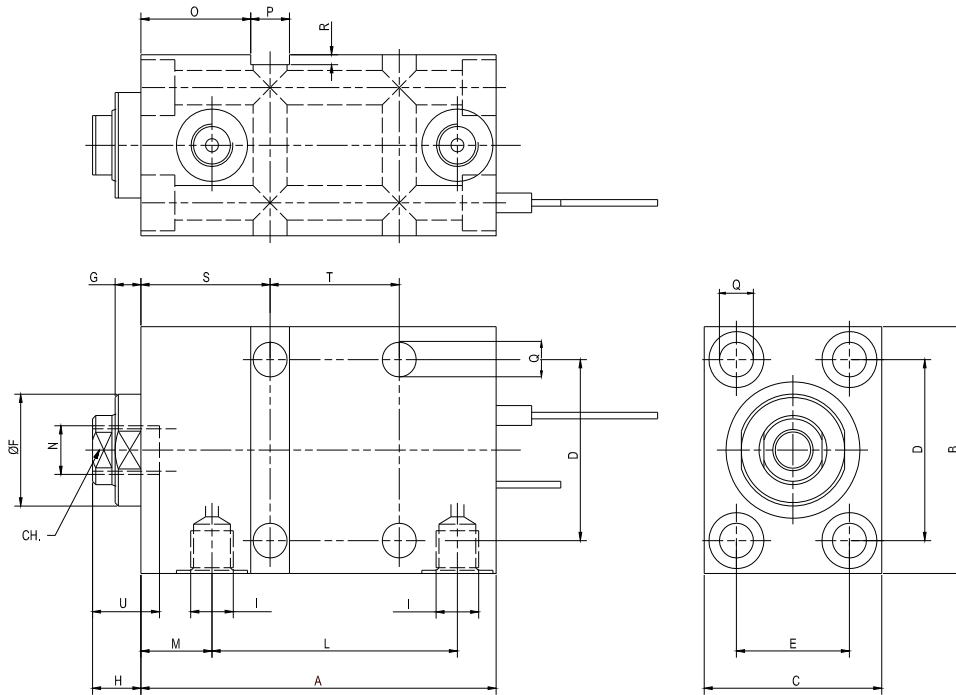

Piston	20		25		32		40		50		63		80		100	
Stem	14		18		22		22		28		28		36		45	
Stroke	20	50	20	50	20	50	20	50	20	50	20	50	20	50	20	50
A	74	104	77	107	80	110	93	123	95	125	105	135	120	150	130	160
B	60		65		75		85		100		115		140		170	
C	40		45		55		63		75		90		110		140	
CH	11		14		18		18		24		24		32		41	
D	45		50		55		63		76		90		110		135	
E	25		30		35		40		45		55		75		95	
F	27		30		34		34		42		50		60		72	
G	5		6,5		8		7		8		7		7		8	
H	12		14		15		17		20		20		20		25	
I	1/4" G.		1/4" G.		1/4" G.		1/4" G.		1/4" G.		3/8" G.		1/2" G.		1/2" G.	
L	42	72	43	73	46	76	55	85	55,5	85,5	55	85	60	90	65	95
M	20		22		22		24		25		29		35		37	
N	M8		M10		M12		M14		M20		M20		M27		M33	
O	28		32		34		37		37,5		47,5		50		60	
P	10		10		12		12		15		15		20		20	
Q	6,5		8,5		10,5		10,5		13		13		17		17	
R	2		2		3		3		5		5		5		5	
S	33		37		40		43		45		55		60		70	
T		40		40		40		45		45		40		40		30
U	16		21		21		28		33		34		38		45	

OIL FEED VARIANTS (WITHOUT FITTING)

FRONT OIL FEEDING

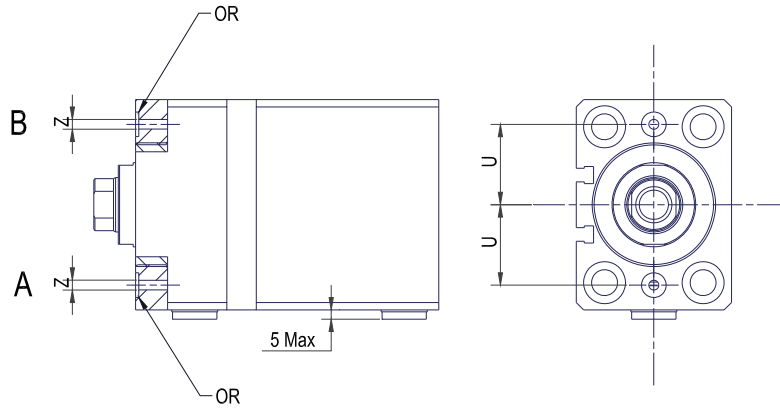

REAR OIL FEEDING

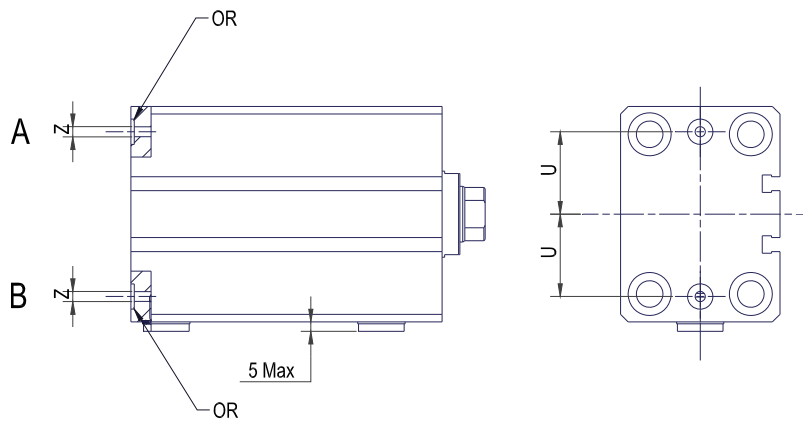

BOTTOM BASE OIL FEEDING

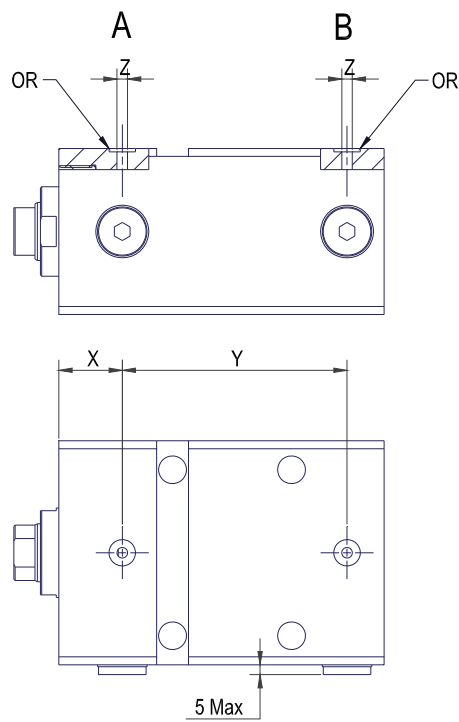

OIL FEED VARIANTS DIMENSIONS (WITHOUT FITTING)

Piston	20		25		32		40		50		63		80		100	
Stroke	20	50	20	50	20	50	20	50	20	50	20	50	20	50	20	50
U	21		25,5		30		32,5		40		48		59		70	
X	20		22		22		24		25		29		35		37	
Y	42	72	43	73	46	76	55	85	55,5	85,5	55	85	60	90	65	95
Z	4		4		4		4		7		7		7		7	
OR	OR 106		OR 106		OR 106		OR 106		OR 108		OR 108		OR 108		OR 108	

STEM ACCESSORIES

Male terminal EM

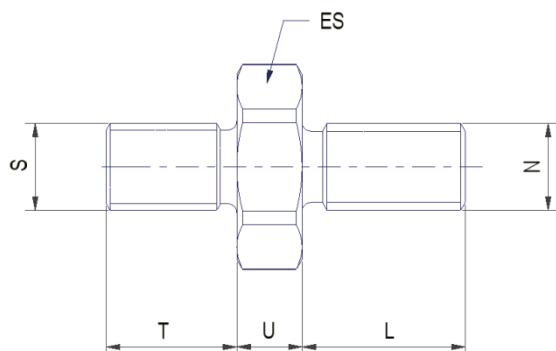

Hammer head ET

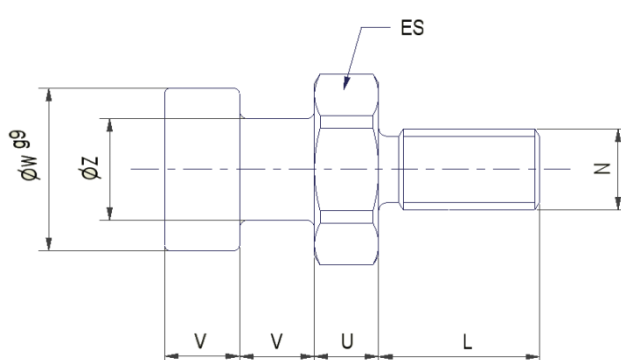

Type		ES	L	N	S	T	U	V	W g9	Z
EM-20	ET-20	17	15	M8	M8 x 1	12	6	7	16	10
EM-25	ET-25	17	20	M10	M10 x 1,25	14	6	7	16	10
EM-32	ET-32	19	20	M12	M12 x 1,25	16	7	8	18	11
EM-40	ET-40	22	25	M14	M14 x 1,5	18	8	8	18	11
EM-50	ET-50	30	30	M20	M20 x 1,5	28	9	10	22	14
EM-63	ET-63	30	30	M20	M20 x 1,5	28	9	10	22	14
EM-80	ET-80	36	40	M27	M27 x 2	36	12	12,5	28	18
EM-100	ET-100	46	50	M33	M33 x 2	45	14	16	35	22

MAGNETIC SENSORS

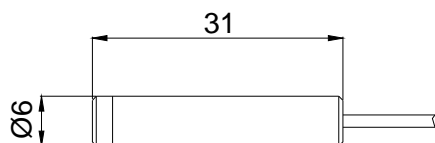

Circuit type

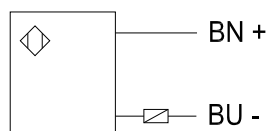

TECHNICAL CHARACTERISTICS	
Voltage	1..130 V AC/DC
Max. current	500 mA
Protection degree	IP 67 (DIN 40050)
Cable	2 x 0.25 mm ²
Length	2000 mm
Contact	N.O.

TECNOFLUID ENGINEERING srl
Via Dei Mille,1 20031 CESANO MADERNO (MB)
TEL. 0362.645981 FAX 0362.645999
e-mail info@tecnofluid.info www.tecnofluid.info