



CY and CZ series cylinders are produced complying the ISO 15552 norm: they have bores between 32 and 125 mm. Particularly indicated where precision is important, they are available in different versions: double effect, cushioned and magnetic. The new and clean tube profile makes the cylinder excellent also from the aesthetic side. The production of special cylinders on customer's drawing is possible, as well as the realization of versions with different seals configurations.

Les vérins série CY et CZ sont conformes aux normes ISO 15552 et vont de l'alésage 32 à 125 mm. Le mouvement du vérin est très précis et différentes versions existent : double effet, magnétique ou non, avec ou sans amortissement, joints Viton haute température. Le nouveau profil du tube, rend le vérin intéressant et esthétique. La production de vérins spéciaux est possible selon le besoin du client.

I cilindri serie CY e CZ di Airwork sono realizzati rispettando la normativa ISO 15552 ed hanno alesaggi compresi tra 32 e 125 mm. Doppio effetto, ammortizzati e magnetici sono indicati dove è richiesta precisione ed affidabilità. Il nuovo profilo della camicia rende il prodotto interessante anche dal punto di vista estetico. Possibili realizzazioni speciali a disegno e molteplici possibilità di scelta per le guarnizioni.

ORDERING CODE / CODIFICATION / CHIAVE DI CODIFICA

CY001000000

Stroke / Course / Corsa

Ø cylinder / Ø vérin / Ø cilindro



On request Atex version:
Sur demande version Atex:
 Su richiesta versione Atex:
 Ex II 2G Ex h II c T6 Gb
 Ex II 2D Ex h III c T80°C Db

VERSION / VERSION / VERSIONE

01	Double acting magnetic cushioned Double effet magnétique amorti Doppio effetto magnetico ammortizzato	
03	Through rod magnetic cushioned Tige traversante magnétique amorti Stelo passante magnetico ammortizzato	
05	For rod lock BS series Sur longueur pour bloqueur BS Con extrastelo per bloccastelo BS	
07	With inox rod Tige inox Con stelo inox	
21	Tandem double push Tandem double poussée Tandem doppia spinta	
23	Tandem double stroke Tandem double course Tandem doppia corsa	
25	Tandem contrasted Tandem opposé Tandem contrapposti	
31	With rubber bellows Avec soufflet Con soffiello	
33	With rod lock BS assembled / avec blo- Queur de tige BS monté Con bloccastelo serie BS montato	

For other versions, please contact our sales department.
Pour les autres versions, veuillez contacter notre service commercial.
 Per altre versioni, contattare il nostro ufficio commerciale.

SEALS / JOINTS / GUARNIZIONI

1	Standard Standard Standard	Polyurethane / Polyuréthane / Poliuretano (-20°C +80°C)
3	High temperature Haute température Alta temperatura	Viton / Viton / Viton (-10°C +150°C)
4	Heavy use Utilisation lourde Uso pesante	Polyurethane / Polyuréthane / Poliuretano (-20°C +80°C)
6	High temperature Haute température Alta temperatura	Viton on the rod / Viton sur la tige / Viton sullo stelo (-10°C +150°C)
8	Low temperature Basse température Bassa temperatura	Polyurethane / Polyuréthane / Poliuretano (-40°C +80°C)
M	Extreme use Utilisation extrême Uso estremo	Metal scraper / Racleur métal / Guarnizione metallica (-20°C +80°C)
A	Standard with aluminium piston Standard avec piston aluminium Standard con pistone alluminio	Polyurethane / Polyuréthane / Poliuretano (-20°C +80°C)

For details see next page / **Pour plus de détails, voir la page suivante** / Per i dettagli vedi pagina seguente

SERIES / SÉRIES / SERIE
CY CY series profile / **Profil de la série CY** / Profilo serie CY

CZ CZ series profile / **Profil de la série CZ** / Profilo serie CZ

For details see next page / **Pour plus de détails, voir la page suivante** / Per i dettagli vedi pagina seguente

TECHNICAL DATA / DONNÉES TECHNIQUES / DATI TECNICI

Sizes / Alésage / Alesaggi	Ø32-40-50-63-80-100-125
Standard strokes / Course standard / Corse standard	mm 25-50-80-100-125-160-200-250-320-350-400-500-600-700-800-900-1000
Fluid / Fluide / Fluido	Lubricated or non lubricated air / Air lubrifié ou non / Aria con o senza lubrificazione
Operating temperature range / Température d'utilisation / Temperatura di esercizio	(-20°C +80°C) (-10°C +150°C) (-40°C +80°C)
Max operating pressure / Pression max d'utilisation / Pressione massima di esercizio	10 bar
Force / Force / Forza sviluppata	Technical informations page / Page informations techniques / Pagina dati tecnici
Air consumption / Consommation d'air / Consumo aria	Technical informations page / Page informations techniques / Pagina dati tecnici

CY TUBE PROFILE / TUBE PROFILE CY / PROFILO TUBO CY

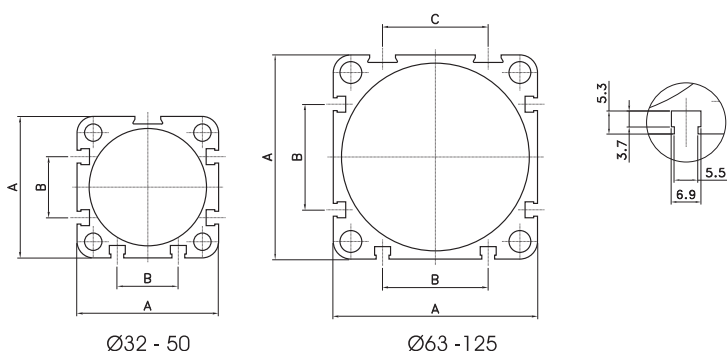

DIMENSIONS / DIMENSIONS / DIMENSIONI

Ø	A	B	C
32	44.5	17	--
40	50.5	23	--
50	60.3	26	--
63	70	37	35
80	87	45	45
100	106	50	46
125	132	56	50

CZ TUBE PROFILE / TUBE PROFILE CZ / PROFILO TUBO CZ

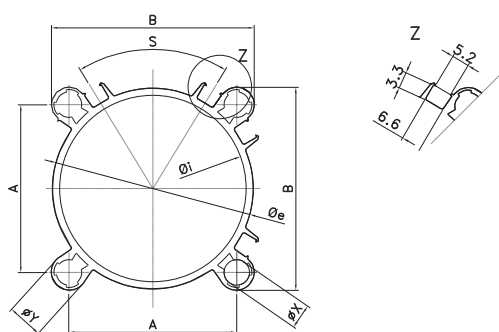

DIMENSIONS / DIMENSIONS / DIMENSIONI

Øi	Øe	A	B	ØX	ØY	S
32 ^{H11}	36	32.5	42.5	5.4	10	46°
40 ^{H11}	44.2	38	48	5.4	10	51°
50 ^{H11}	54.4	46.5	59.5	7.4	13	54°
63 ^{H11}	67.7	56.5	69.5	7.4	13	61°
80 ^{H11}	85.5	72	86	9.1	14	65°
100 ^{H12}	105.5	89	105.5	9.1	16.5	68°
125 ^{H12}	131	110	131	10.6	17	70°

SEALS / JOINTS / GUARNIZIONI

CODE	PHOTO PHOTO FOTO	SEALS JOINTS GUARNIZIONI	MATERIAL - TEMPERATURE MATÉRIEL - TEMPÉRATURE MATERIALE - TEMPERATURA	FEATURES CARACTÉRISTIQUES CARATTERISTICHE
1		Standard Standard Standard	Polyurethane Polyuréthane Poliuretano (-20°C +80°C)	These are the seals that are mounted on the standard version for a trouble-free use. Ce sont les joints qui sont montés sur la version standard pour une utilisation sans problème. <i>Sono le guarnizioni che vengono montate sulla versione standard per un utilizzo senza problematiche.</i>
3		High temperature Haute température Alta temperatura	Viton Viton Viton (-10°C +150°C)	Solution indicated in the presence of both peaks and constant heat. Solution indiquée en présence de pics de chaleur et de chaleur constante. <i>Soluzione indicata in presenza sia di picchi che di calore costante.</i>
4		Heavy use Utilisation lourde Uso pesante	Polyurethane Polyuréthane Poliuretano (-20°C +80°C)	Seal for severe use such as: dirt of various types, adhesive material, grease etc. Joint pour une utilisation sévère comme: saleté de divers types, matériel adhésif, graisse etc. <i>Guarnizione per utilizzo severo come: sporcizia di vario tipo, materiale adesivo, grasso ecc.</i>
6		High temperature Haute température Alta temperatura	viton only on the rod viton uniquement sur la tige <i>viton solo sullo stelo</i> (-10°C +150°C)	Viton seal only on the rod, this solution is adopted when there are no large sources of heat or only peaks of heat. Joint en Viton seulement sur la tige, cette solution est adoptée quand il n'y a pas de grandes sources de chaleur ou seulement des pics de chaleur. <i>Guarnizione in viton solo sullo stelo, Questa soluzione viene adottata quando non sono presenti grandi fonti di calore oppure solo picchi di calore.</i>
8		Low temperature Basse température Bassa temperatura	Polyurethane Polyuréthane Poliuretano (-40°C + 80°C)	Ideal solution for applications with very low temperatures. Solution idéale pour les applications à très basses températures. <i>Soluzione indicata per applicazioni con temperature molto basse.</i>
M		Extreme use Utilisation extrême Uso estremo	Metal scraper Racleur métal <i>Guarnizione metallica</i> (-20°C +80°C)	Seal with metal outer lip able to remove any element deposited on the rod such as: welding sparks or ice even of great thickness. Joint avec lèvres extérieure en métal capable d'enlever tout élément déposé sur la tige comme: étincelles de soudure ou glace même de grande épaisseur. <i>Guarnizione con labbro esterno in metallo capace di asportare qualsiasi elemento depositato sullo stelo come: scintille di saldatura oppure ghiaccio anche di grande spessore.</i>

THE KEY POINTS / LES POINTS CLES / PUNTI DI FORZA

Version with seal for heavy use and difficult environments.
Version avec joint pour utilisation lourde et dans environnements difficiles.
 Versione con guarnizione per uso pesante e ambienti difficili.

It's possible to have the piston in aluminium or acetal resin.
Il est possible d'avoir le piston en aluminium ou en résine acétal.
 È possibile avere il pistone in alluminio o resina acetilica.

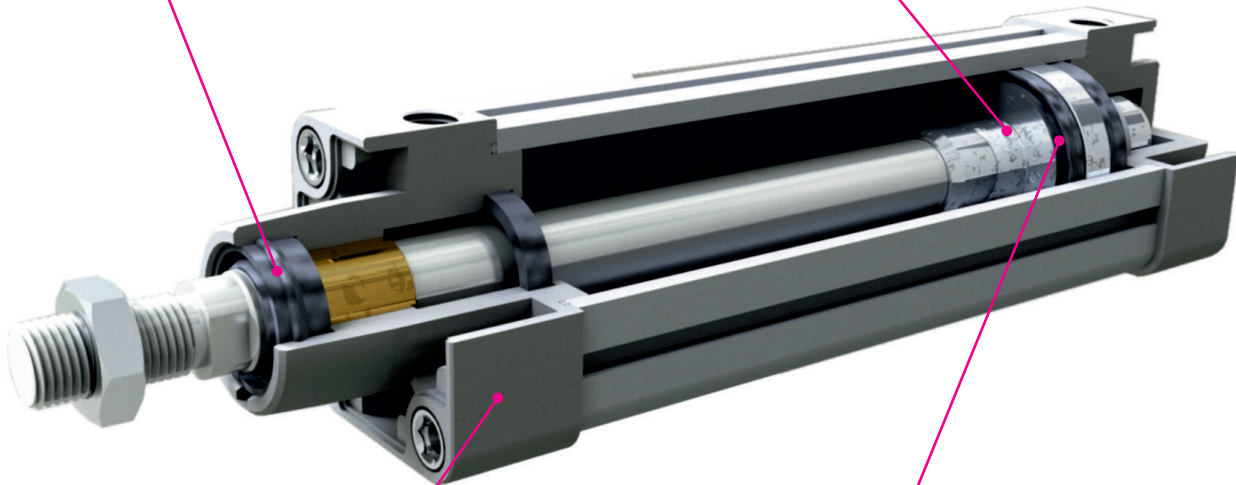

All seals are in polyurethane with high wear resistance.
Tous les joints sont en polyuréthane à haute résistance à l'usure.
 Tutte le guarnizioni sono in poliuretano con elevata resistenza all'usura.

Heads are extremely elegant with an high aesthetic impact thanks to epoxy paint which is resistant to corrosion.
Les fonds sont extrêmement élégants avec un haut impact esthétique grâce à la peinture époxy qui est résistante à la corrosion.
 Le testate sono estremamente eleganti, con un grande impatto estetico grazie alla vernice epossidica resistente alla corrosione.

CUSHIONABLE LOAD / COURBE DE L'AMORTISSEMENT / CARICO AMMORTIZZABILE

To make cylinder reach its end of stroke position without dangerous hits, it's necessary to annul kinetic energy and relative work produced by moving mass. The maximum value of amortizable load depends on translation speed and absorbance capability of pneumatic cushioning of cylinders. The chart below provides values of speed and amortizable mass for a pressure of 6 bar.

Pour permettre au vérin d'atteindre sa fin de course sans à coups dangereux, il est nécessaire d'annuler l'énergie cinétique et le travail relatif produit. La valeur maximale de la charge amortissable dépend de la vitesse de déplacement et la capacité absorbante de l'amortissement pneumatique du vérin. Le diagramme ci-dessous fournit les valeurs de vitesse et la masse amortissable pour une pression à 6 bar.

Affinché il cilindro raggiunga la posizione di fine corsa senza urti dannosi, occorre annullare l'energia cinetica della massa in movimento ed il relativo lavoro sviluppato. Il valore massimo del carico ammortizzabile dipende dalla velocità di traslazione e dalla capacità di assorbimento dell'amortizzo pneumatico dei cilindri. Il diagramma fornisce i valori di velocità, massa ammortizzabile ad una pressione di 6 bar.

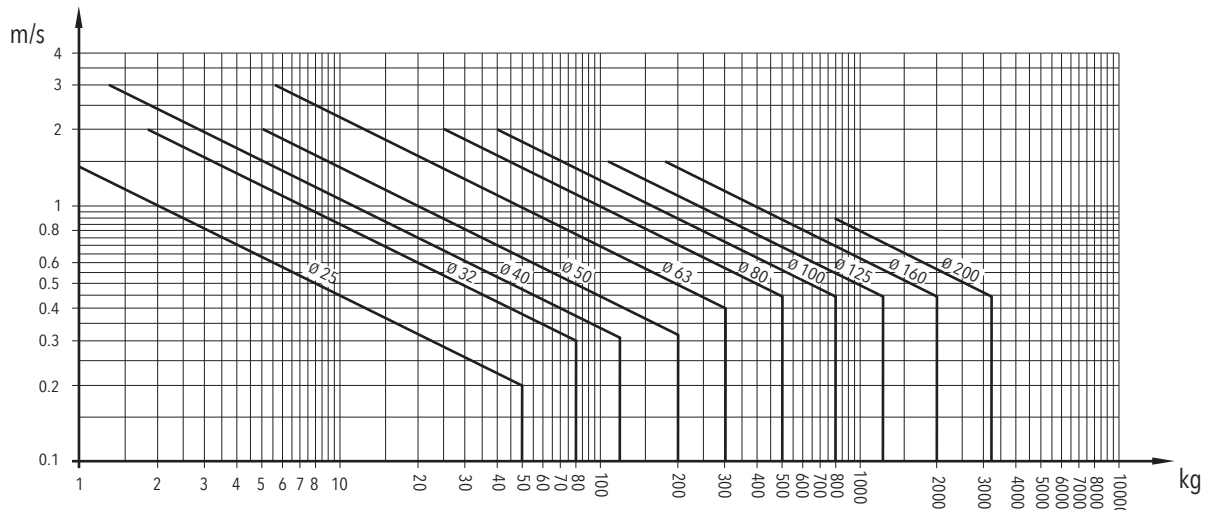

COMPONENTS / COMPOSANTS / COMPONENTI

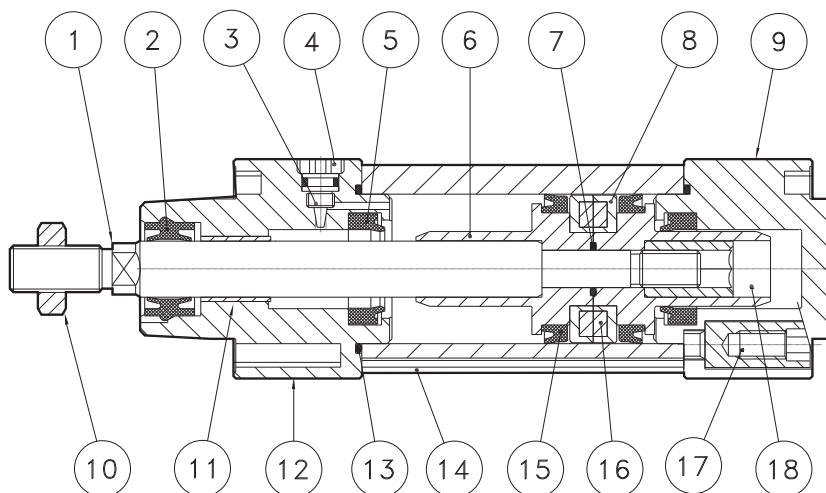

N.	DESCRIPTION / DESCRIPTION / DESCRIZIONE	MATERIAL / MATIÈRE / MATERIALE
1	rod / tige / stelo	steel C40 / acier C40 / acciaio C40
2	rod seal / joints tige / guarnizione stelo	polyurethane / PU / poliuretano
3	regulator cushion screw / vis amortissement / vite ammortizzo	nickel plated brass / laiton nickelé / ottone nichelato
4	stop cushion screw / stop vis / grano ferma vite	nickel plated brass / laiton nickelé / ottone nichelato
5	cushion seal / joint amortissement / guarnizione ammortizzo	polyurethane / PU / poliuretano
6	half piston / semi piston / semipistone	POM or aluminium / aluminium / alluminio
7	o-ring	NBR
8	guide piston / guide piston / guida pistone	POM
9	rear cap / fond arrière / testata posteriore	aluminium / aluminium / alluminio

N.	DESCRIPTION / DESCRIPTION / DESCRIZIONE	MATERIAL / MATIÈRE / MATERIALE
10	nut / écrou / dado	zinc plated steel / acier zingué / acciaio zincato
11	guide bush / bague guidage / bussola guida	bronze / bronze / bronzo
12	front cap / nez avant / testata anteriore	aluminium / aluminium / alluminio
13	o-ring	NBR
14	tube / tube / tubo	aluminium / aluminium / alluminio
15	piston seal / joint piston / guarnizione pistone	polyurethane / PU / poliuretano
16	magnet / aimant / magnete	plastroferrite
17	fixing cap screw / vis de tête / vite testata	zinc plated steel / acier zingué / acciaio zincato
18	fixing piston nut / écrou / dado fissaggio pistone	zinc plated steel / acier zingué / acciaio zincato

SEALS KIT / KIT JONTS / KIT GUARNIZIONI

K Z 0 1 1 0 0 0

→ Ø cylinder / Ø vérin / Ø cilindro
 → SEALS / JOINTS / GUARNIZIONI

1	Standard Standard Standard	Polyurethane / Polyuréthane / Poliuretano (-20°C +80°C)
3	High temperature Haute température Alta temperatura	Viton/ Viton / Viton (-10°C +150°C)
4	Heavy use Utilisation lourde Uso pesante	Polyurethane / Polyuréthane / Poliuretano (-20°C +80°C)
6	High temperature Haute température Alta temperatura	Viton only on the rod / Viton uniquement sur la tige / Viton solo sullo stelo (-10°C +150°C)
8	Low temperature Basse température Bassa temperatura	Polyurethane / Polyuréthane / Poliuretano (-40°C + 80°C)
M	Extreme use Utilisation extrême Uso estremo	Metal scraper / Racleur métal / Guarnizione metallica (-20°C +80°C)

Double acting cushioned
Double effet amorti
 Doppio effetto ammortizzato

CODE: CY011.Ø.mm



CODE: CZ011.Ø.mm

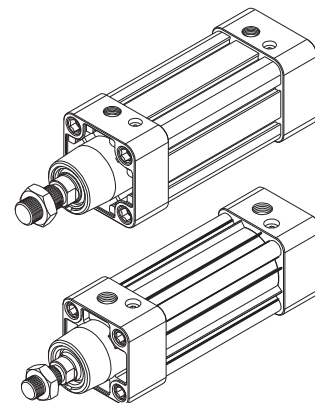
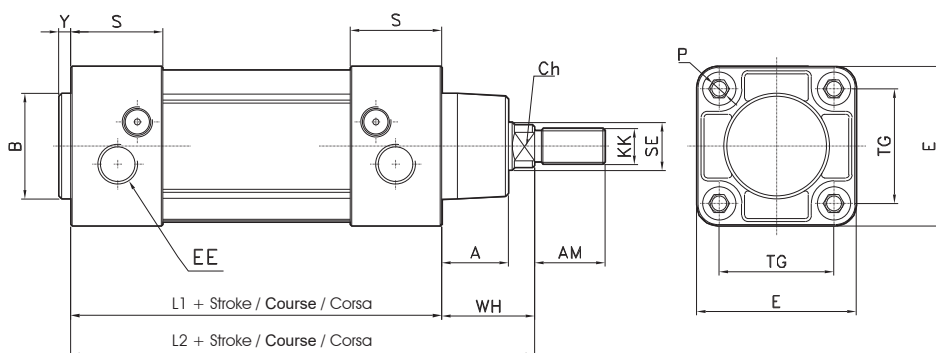
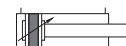

Ø	A	AM	B e11	E	EE	Y	KK	L1	L2	P	S	Ø SE	TG	WH	CH
32	20	22	30	47	G1/8"	4	M10x1.25	94	120	M6	28	12	32.5	26	10
40	22	24	35	53	G1/4"	4	M12x1.25	105	135	M6	30.5	16	38	30	13
50	28	32	40	65	G1/4"	4	M16x1.5	106	143	M8	31	20	46.5	37	16
63	28	32	45	75	G3/8"	4	M16x1.5	121	158	M8	35	20	56.5	37	16
80	34	40	45	95	G3/8"	4	M20x1.5	128	174	M10	36	25	72	46	21
100	38	40	55	115	G1/2"	4	M20x1.5	138	189	M10	41	25	89	51	21
125	50	54	60	140	G1/2"	5	M27x2	160	225	M12	45	32	110	65	27

Through rod cushioned
Tige traversante amorti
 Stelo passante ammortizzato

CODE: CY031.Ø.mm

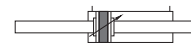

CODE: CZ031.Ø.mm

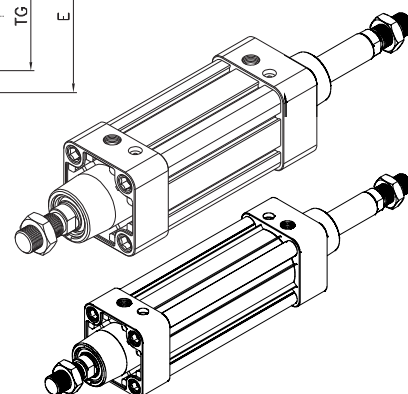
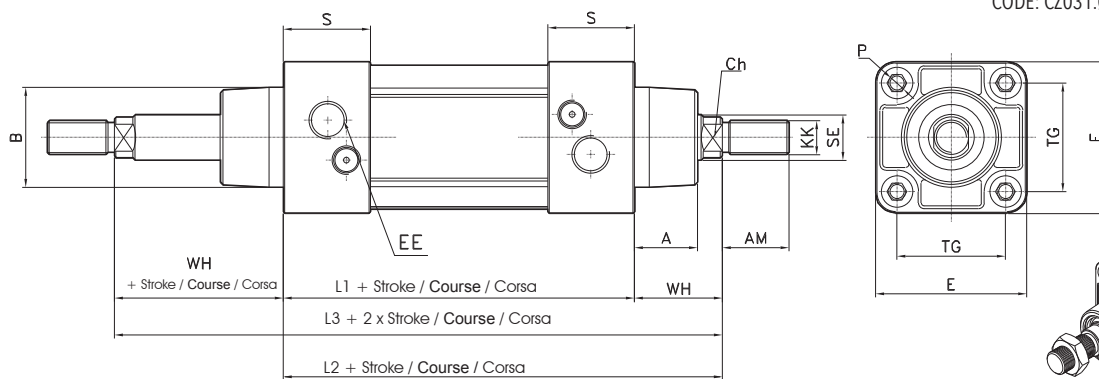
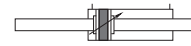

Ø	A	AM	B e11	E	EE	KK	L1	L2	L3	P	S	Ø SE	TG	WH	CH
32	20	22	30	47	G1/8"	M10x1.25	94	120	146	M6	28	12	32.5	26	10
40	22	24	35	53	G1/4"	M10x1.25	105	135	165	M6	30.5	16	38	30	13
50	28	32	40	65	G1/4"	M16x1.5	106	143	180	M8	31	20	46.5	37	16
63	28	32	45	75	G3/8"	M16x1.5	121	158	195	M8	35	20	56.5	37	16
80	34	40	45	95	G3/8"	M20x1.5	128	174	220	M10	36	25	72	46	21
100	38	40	55	115	G1/2"	M20x1.5	138	189	240	M10	41	25	89	51	21
125	50	54	60	140	G1/2"	M27x2	160	225	290	M12	45	32	110	65	27

Tandem double push
Tandem double poussée
 Tandem doppia spinta

CODE: CY211.Ø.mm



CODE: CZ211.Ø.mm

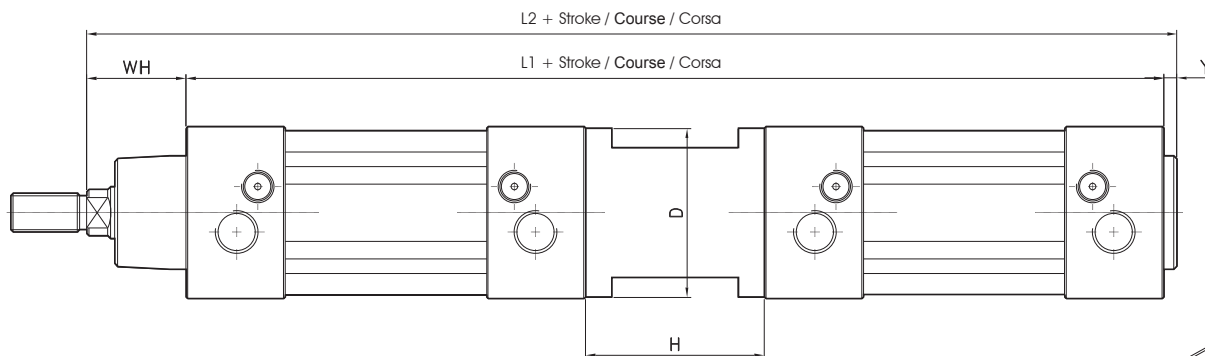

Ø	H	D	WH	L1	L2	Y
32	55	45	26	243	273	4
40	55	52	30	265	299	4
50	68	65	37	280	321	4
63	68	75	37	314	351	4
80	92	95	46	348	398	4
100	92	115	51	368	423	4
125	120	140	65	440	510	5

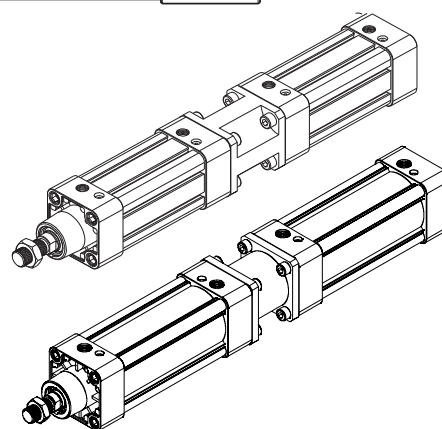

Tandem contrasted
Tandem opposé
 Tandem contrapposti

CODE: CY251.Ø.mm



CODE: CZ251.Ø.mm

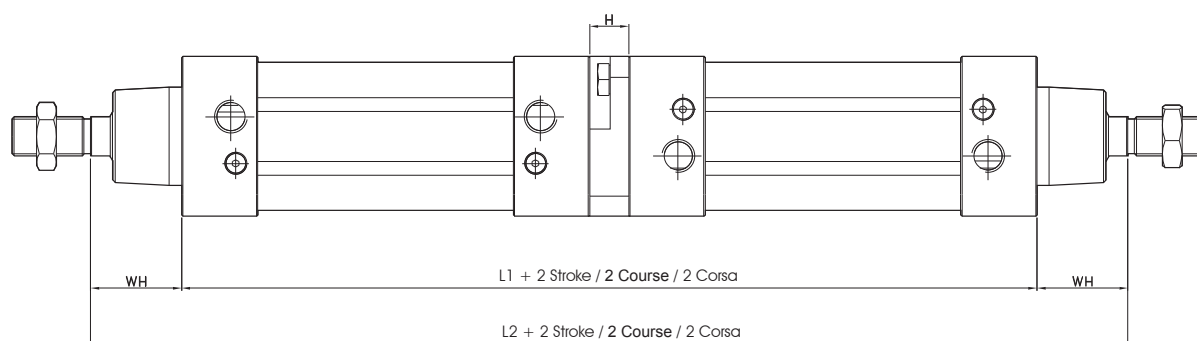

Ø	H	WH	L1	L2
32	12	26	200	252
40	12	30	222	282
50	16	37	228	302
63	16	37	258	332
80	20	46	276	368
100	20	51	296	398
125	30	65	350	480

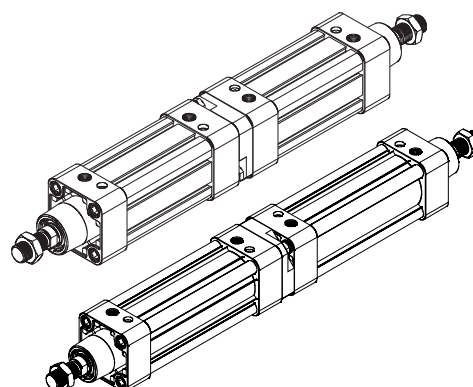

With rubber bellow
Avec soufflet
 Con soffiello

CODE: CY311.Ø.mm

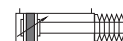

CODE: CZ311.Ø.mm

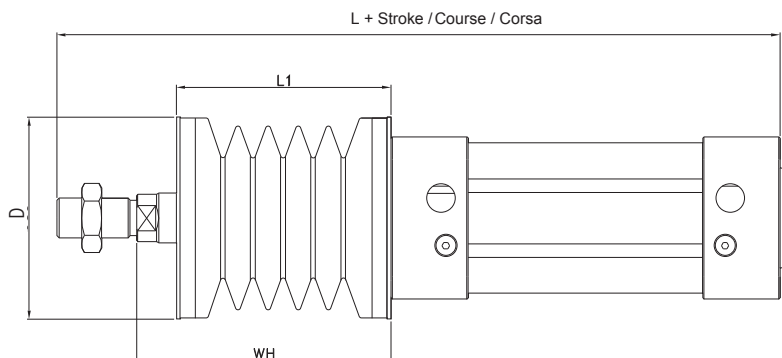
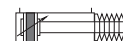

Ø	D	Stroke/Course/Corsa								
		<300mm			<600mm			<900mm		
		L	L1	WH	L	L1	WH	L	L1	WH
32	83	196	65	80	261	130	145	316	195	200
40	83	209	65	80	274	130	145	329	195	200
50	83	218	65	80	283	130	145	338	195	200
63	83	233	65	80	298	130	145	353	195	200
80	83	248	65	80	313	130	145	371	195	200
100	106	233	40	55	273	80	95	313	120	135
125	106	274	40	60	314	80	100	354	120	140

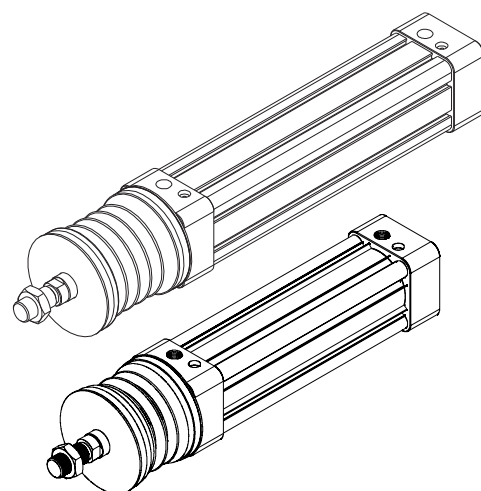

With rod lock BS series assembled
Avec bloqueur de tige serie BS monté
 Con bloccastelo serie BS montato

CODE: CY331.Ø.mm



CODE: CZ331.Ø.mm

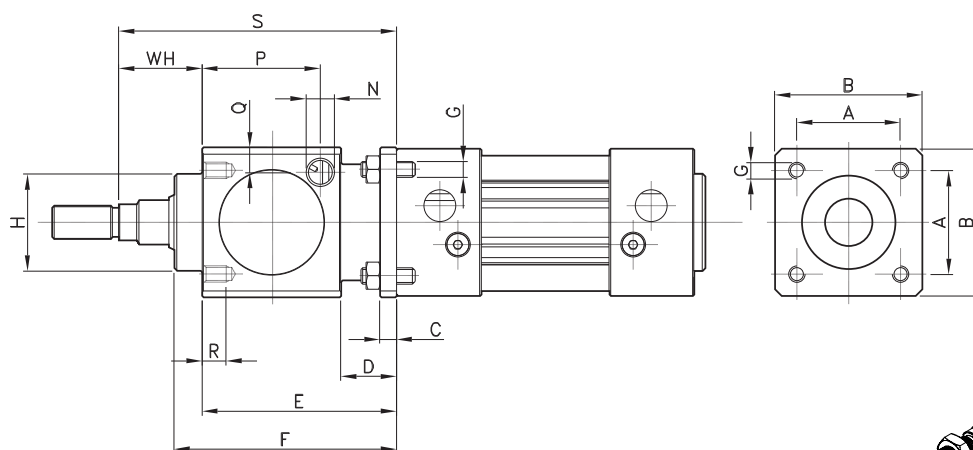

Ø	A	B	C	D	E	F	G	H	N	P	Q	R	S	T
32	32.5	47	6	20	60	67.5	M6	30	1/8"G	33.25	9	8	86	60
40	38	54	6	20	70	80	M6	34.9	1/8"G	42.5	9	8	100	70
50	46.5	65	8	24	90	100	M8	40	1/8"G	58	12.5	12	127	90
63	56.5	75	8	24	90	100	M8	45	1/8"G	59	17.5	12	127	90
80	72	95	12	32	110	120	M10	45	1/4"G	69	17.5	16	156	110
100	89	114	12	32	110	120	M10	55	1/4"G	69	20	16	161	110
125	110	138	20	45	140	156	M12	60	1/4"G	84.5	19	20	205	140

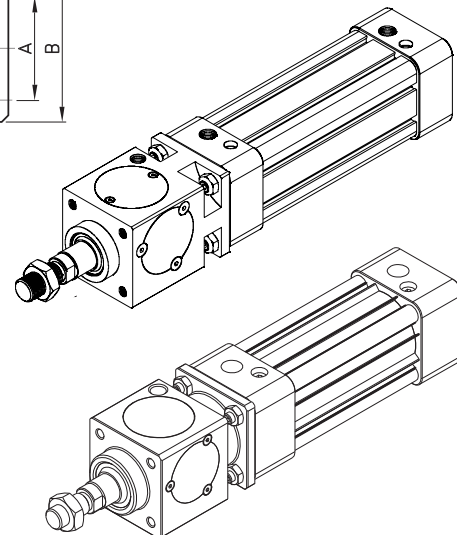

MOUNTING PARTS / ACCESSOIRES DE MONTAGE / ACCESSORI DI FISSAGGIO

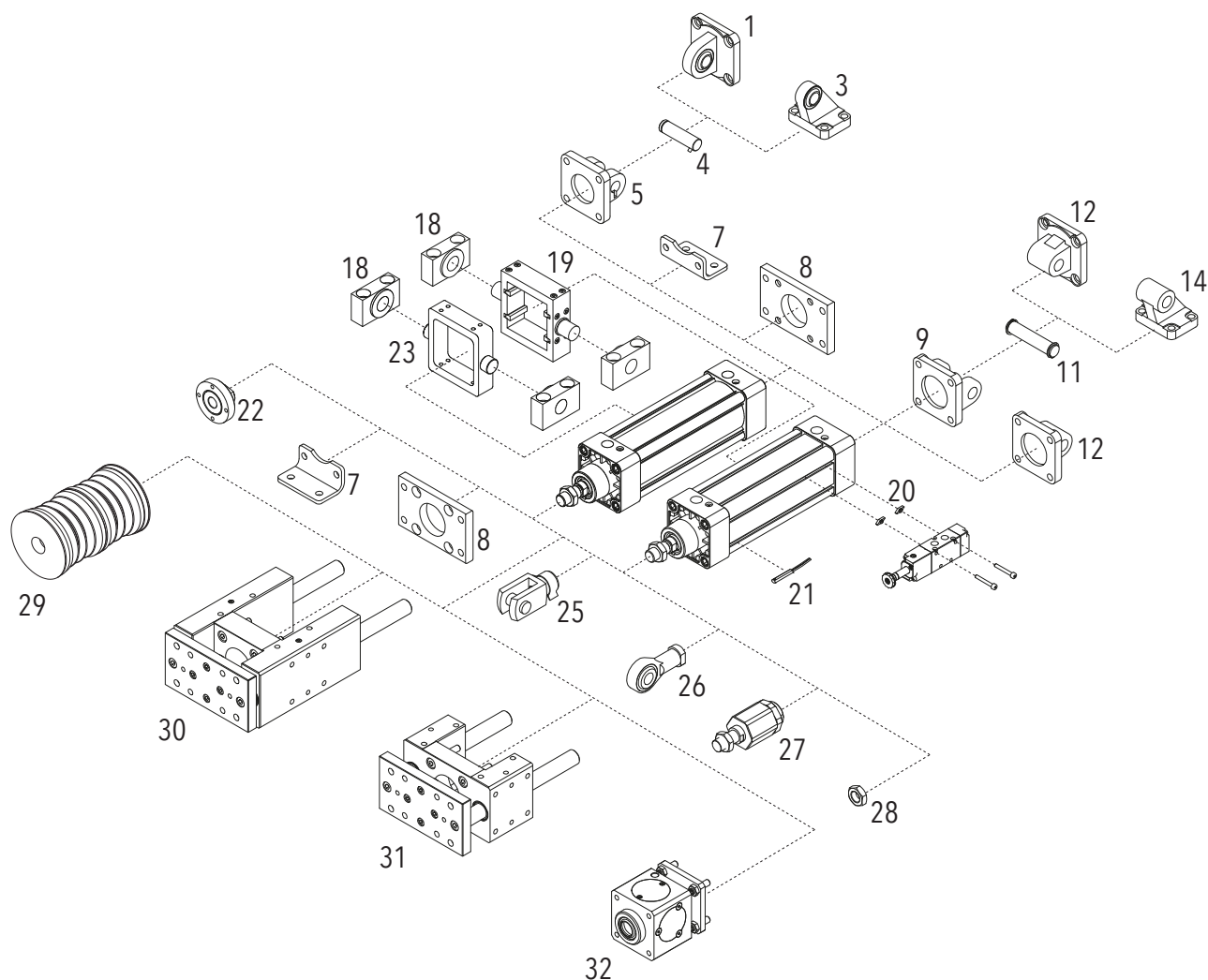

POS.	DESCRIPTION DESCRIPTION DESCRIZIONE	ALUMINIUM ALUMINIUM ALLUMINIO	STEEL ACIER ACCIAIO	POS.	DESCRIPTION DESCRIPTION DESCRIZIONE	ALUMINIUM ALUMINIUM ALLUMINIO	STEEL ACIER ACCIAIO
1	Male hinge with articulated head / Chape mâle arrière rotulée / Cerniera maschio con testa snodata	AR4226. Ø -V	AR4261. Ø -V	20	Valve fixing plaque / Fixation pour valve / Piastrina fissaggio valvola		AR4213
3	Square joint artic.head / Artic. arrière equerre rotulée / Articolazione a squadra snodata		AR4208. Ø	21	Oval switch / Capteur oval / Sensore ovale	AR4019...	
4	Pin anti-rotation / Axe anti-rotation / Perno antirotazione		AR41803. Ø	22	Floating joint / Guide flottant / Giunto flottante		KU0017. Ø
5	Narrow female hinge / Chape femelle étroite / Cerniera femmina stretta	AR41801. Ø -V	AR4212. Ø -V	23	Intermediate hinge / Tourillon Intermédiaire / Cerniera intermedia		AR4279. Ø
7	Pedestal / Equerre / Piedino		AR4152. Ø -V	25	Yoke / Fourche / Forcella		AR4067...
8	Flange / Bride / Flangia		AR4151. Ø -V	26	Rod ends / Chape de tige rotulée / Testa a snodo		AR4066...
9	Female hinge / Chape arrière femelle / Cerniera femmina	AR4147. Ø -V	AR4184. Ø -V	27	Self-aligning joint / Chape Auto-Alignante / Giunto autoallineante		AR406...
11	Pivot for hinge / Axe chape arrière / Perno per cerniera		AR4150. Ø	28	Nut for rod / Ecrou de tige / Dado per stelo		DAD...
12	Male hinge / Chape mâle arrière / Cerniera maschio	AR4149. Ø -V	AR4186. Ø -V	29	Rubber bellows / Soufflet / Soffietto		
14	Square joint / Articulation equerre / Articolazione a squadra	AR4156. Ø	AR4207. Ø	30	Guide unit H type / Unité de guidage en H / Unità guida ad H	UG2014. Ø	
18	Support for inter. Hinge / Support pour tourillon / Supporto cerniera intermedia		AR4159. Ø	31	Guide unit U type / Unité de guidage en U / Unità guida ad U	UG2008. Ø	
19	Intermediate hinge / Tourillon Intermédiaire / Cerniera intermedia	AR4158. Ø		32	Rod lock / Bloqueur de tige / Bloccastelo	BS... Ø	

**PEDESTAL
 EQUERRE
 PIEDINO**

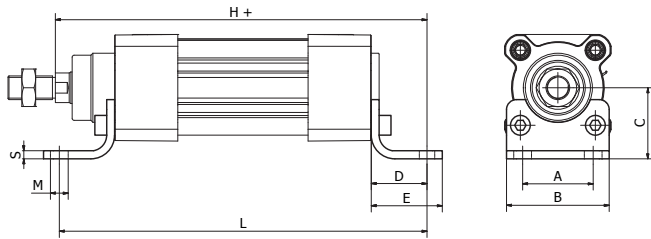
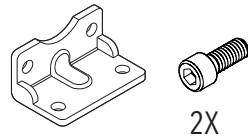

CODE MATERIAL / MATIÈRE / MATERIALE
AR4152 Ø-V Steel / Acier / Acciaio

Ø	A	B	C	D	E	H	L	M	S	weight (g)
032	32	45	32	24	35	144	142	7	4	66
040	36	52	36	28	36	163	161	9	4	78
050	45	65	45	32	47	175	170	9	5	168
063	50	75	50	32	45	190	185	9	5	190
080	63	95	63	41	55	215	210	12	6	382
100	75	115	71	41	57	230	220	14	6	452
125	90	140	90	45	70	270	250	16	8	1090

**FLANGE
 BRIDE
 FLANGIA**

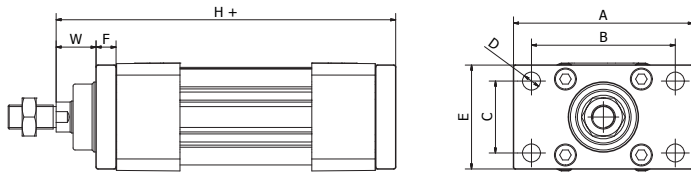
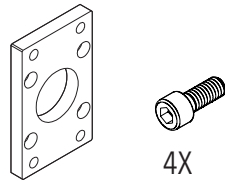

CODE MATERIAL / MATIÈRE / MATERIALE
AR4151 Ø-V Steel / Acier / Acciaio

Ø	A	B	C	D	E	F	H	W	weight (g)
032	80	64	32	7	45	10	130	16	190
040	90	72	36	9	52	10	145	20	246
050	110	90	45	9	65	12	155	25	478
063	120	100	50	9	75	12	170	25	622
080	150	126	63	12	95	16	190	30	1430
100	170	150	75	14	115	16	205	35	1986
125	205	180	90	16	140	20	245	45	3750

**MALE HINGE
 CHAPE MALE ARRIERE
 CERNIERA MASCHIO**

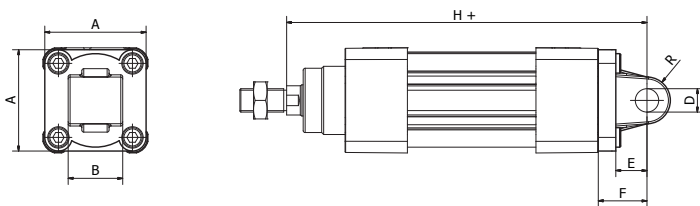
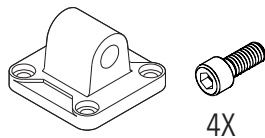

CODE MATERIAL / MATIÈRE / MATERIALE
AR4149 Ø-V Aluminium / Aluminium / Alluminio
AR4186 Ø-V Steel / Acier / Acciaio

Ø	A	B	D	E	F	H	R	weight (g)	weight (g)
032	45	26	10	13	22	142	10	54	176
040	52	28	12	16	25	160	12	76	274
050	65	32	12	16	27	170	12	124	368
063	75	40	16	21	32	190	16	212	282
080	95	50	16	22	36	210	16	420	1196
100	115	60	20	27	41	230	20	666	2100
125	140	70	25	30	50	275	25	1264	3740

**FEMALE HINGE
 CHAPE ARRIERE FEMELLE
 CERNIERA FEMMINA**

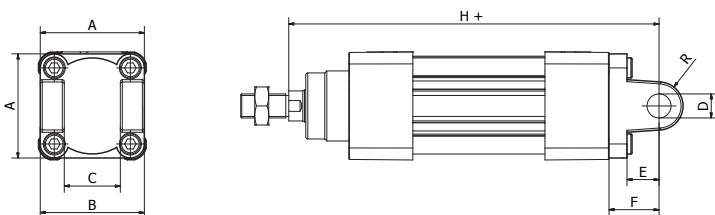
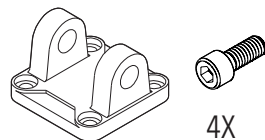

CODE MATERIAL / MATIÈRE / MATERIALE
AR4147 Ø-V Aluminium / Aluminium / Alluminio
AR4184 Ø-V Steel / Acier / Acciaio

Ø	A	B	C	D	E	F	H	R	weight (g)	weight (g)
032	45	45	26	10	13	22	142	10	48	138
040	52	52	28	12	16	25	160	12	75	230
050	65	60	32	12	16	27	170	12	124	338
063	75	70	40	16	21	32	190	16	192	540
080	95	90	50	16	22	36	210	16	380	1000
100	115	110	60	20	27	41	230	20	620	1700
125	140	130	70	25	30	50	275	25	1180	3350

PIVOT FOR FEMALE HINGE
AXE POUR CHAPE FEMELLE
 PERNO PER CERNIERA FEMMINA

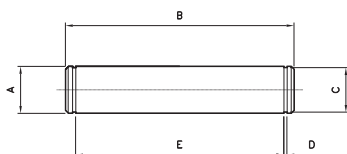
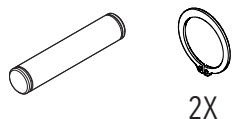

CODE MATERIAL / MATIÈRE / MATERIALE
AR4150 Ø Steel / Acier / Acciaio

Ø	A	B	C	D	E	weight (g)
032	10	53	9.6	1.1	46	32
040	12	60	11.5	1.1	53	52
050	12	68	11.5	1.1	61	60
063	16	78	15.2	1.1	71	122
080	16	98	15.2	1.1	91	152
100	20	118	19	1.3	111	290
125	25	139	23.9	1.3	132	530

NARROW FEMALE HINGE
CHAPE ARRIERE FEMELLE ÉTROITE
 CERNIERA FEMMINA STRETTA

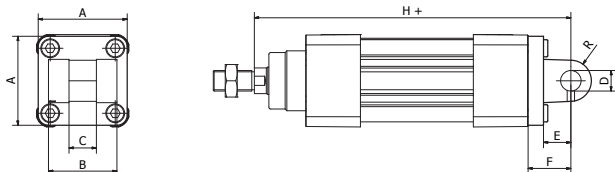
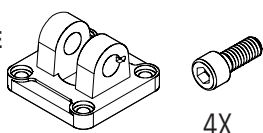

CODE MATERIAL / MATIÈRE / MATERIALE
AR41801 Ø-V Aluminium / Aluminium / Alluminio
AR4212 Ø-V Steel / Acier / Acciaio

Ø	A	B	C	D	E	F	H	R	weight (g)	weight (g)
032	45	34	14	10	13	22	142	10	42	140
040	52	40	16	12	16	25	160	12	70	230
050	65	45	21	16	16	27	170	14	112	336
063	75	51	21	16	21	32	190	18	194	546
080	95	65	25	20	22	36	210	20	382	1190
100	115	75	25	20	27	41	230	22	610	1840
125	140	97	37	30	30	50	275	25	1100	3550

PIN ANTI-ROTATION FOR NARROW FEMALE HINGE
AXE ANTI-ROTATION POUR CHAPE FEMELLE ÉTROITE
 PERNO ANTIROTAZIONE PER CERNIERA STRETTA

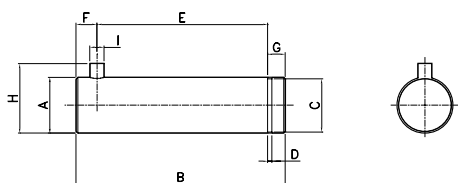
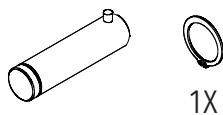

CODE MATERIAL / MATIÈRE / MATERIALE
AR41803 Ø Steel / Acier / Acciaio

Ø	A	B	C	D	E	F	G	H	I	weight (g)
032	10	41	9.6	1.1	32.5	4.5	4	14	3	26
040	12	48	11.5	1.1	38	6	4	16	4	42
050	16	54	15.2	1.1	43	6	5	20	4	84
063	16	60	15.2	1.1	49	6	5	20	4	94
080	20	75	19	1.3	63	6	6	24	4	184
100	20	85	19	1.3	73	6	6	24	4	208
125	30	110	28.6	1.6	94	9	7	36	6	606

MALE HINGE WITH ARTICULATED HEAD
CHAPE ARRIERE ROTULEE
 CERNIERA MASCHIO CON TESTINA SNODATA

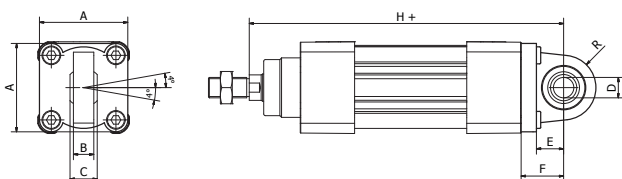
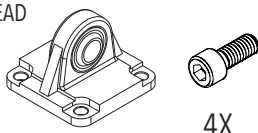

CODE MATERIAL / MATIÈRE / MATERIALE
AR4226 Ø-V Aluminium / Aluminium / Alluminio
AR4261 Ø-V Steel / Acier / Acciaio

Ø	A	B	C	D	E	F	H	R	weight (g)	weight (g)
032	45	10,5	14	10	13	22	142	16	65	152
040	52	12	16	12	16	25	160	19	100	256
050	65	15	21	16	16	27	170	21	180	364
063	75	15	21	16	21	32	190	24	244	595
080	95	18	25	20	22	36	210	28,5	476	1122
100	115	18	25	20	27	41	230	30	646	1786
125	140	25	37	30	30	50	275	40	1410	3500

SQUARE JOINT
ARTICULATION ARRIERE D'EQUERRE
ARTICOLAZIONE A SQUADRA

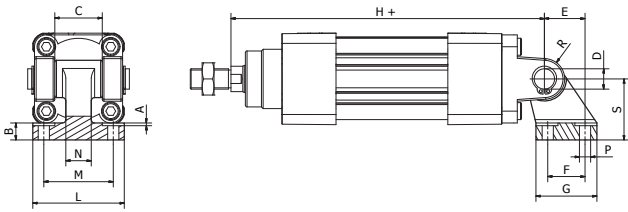
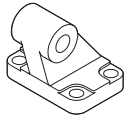

CODE	MATERIAL / MATIÈRE / MATERIALE
AR4156 Ø	Aluminium / Aluminium / Alluminio
AR4207 Ø	Steel / Acier / Acciaio

Ø	A	B	C	D	E	F	G	H	L	M	N	P	R	S	(g)	(g)
032	1.6	8	26	10	21	18	31	142	51	38	10	6.6	10	32	56	158
040	1.6	10	28	12	24	22	35	160	54	41	15	6.6	12	36	80	238
050	1.6	12	32	12	33	30	45	170	65	50	16	9	12	45	142	418
063	1.6	14	40	16	37	35	50	190	67	52	16	9	16	50	200	526
080	2.5	14	50	16	47	40	60	210	86	66	20	11	16	63	312	1055
100	2.5	17	60	20	55	50	70	230	96	76	20	11	20	71	510	1510
125	3.2	20	70	25	70	60	90	275	124	94	30	14	25	90	826	3150

SQUARE JOINT WITH ARTIC. HEAD
ARTICULATION ARRIERE EQUERRE
ARTICOLAZIONE A SQUADRA
CON TESTA SNODATA

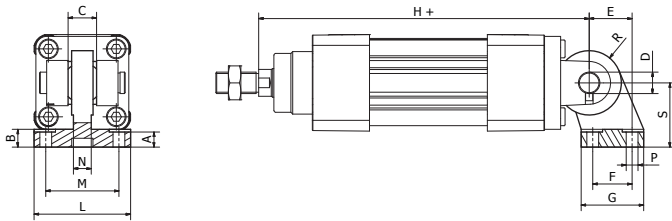
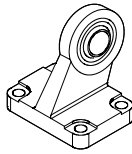

CODE	MATERIAL / MATIÈRE / MATERIALE
AR4208 Ø	Steel / Acier / Acciaio

Ø	A	B	C	D	E	F	G	H	L	M	N	P	R	S	weight (g)
032	8.5	10	14	10	21	18	31	142	51	38	10.5	6.6	15	32	178
040	8.5	10	16	12	24	22	35	160	54	41	12	6.6	18	36	268
050	10.5	12	21	16	33	30	45	170	65	50	15	9	20	45	459
063	10.5	12	21	16	37	35	50	190	67	52	15	9	23	50	550
080	11.5	14	25	20	47	40	60	210	86	66	18	11	27	63	970
100	12.5	15	25	20	55	50	70	230	96	76	18	11	30	71	1326
125	17	20	37	30	70	60	90	275	124	94	25	13.5	40	90	3000

INTERMEDIATE HINGE FOR CY
TOURILLON INTERMEDIAIRE POUR CY
CERNIERA INTERMEDIA PER CY

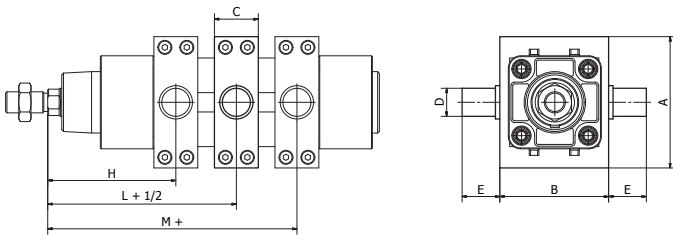
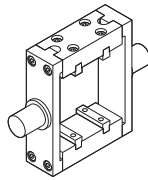

CODE	MATERIAL / MATIÈRE / MATERIALE
AR4158 Ø	Aluminium / Aluminium / Alluminio

Ø	A	B	C	D	E	H	L	M
032	65	52	25	12	17.5	66.5	73.5	79.5
040	74.5	62	25	16	21.5	73	82.5	92
050	90.3	74	25	16	21.5	80.5	90	99.5
063	94.5	91	30	20	23.5	87	97.5	108
080	109.3	111	30	20	23.5	97	110	123
100	134	129	40	25	33	112	120	128
125	160	156.7	40	25	33	130	145	160

INTERMEDIATE HINGE FOR CZ AND CF
TOURILLON INTERMEDIAIRE POUR CZ ET CF
CERNIERA INTERMEDIA PER CZ E CF

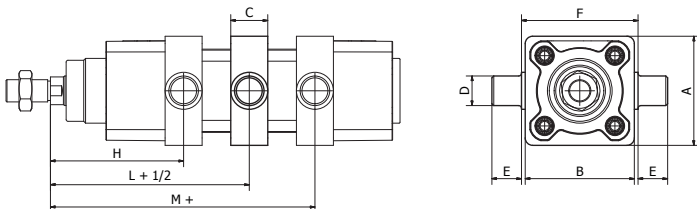
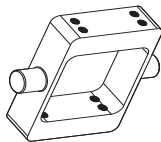

CODE	MATERIAL / MATIÈRE / MATERIALE
AR4279 Ø	Steel / Acier / Acciaio

Ø	A	B	C	D	E	F	H	L	M	weight (g)
032	46	46	15	12	12	50	61.5	73.5	84.5	250
040	59	59	20	16	16	63	70.5	82.5	94.5	410
050	69	69	20	16	16	75	78	90	102	530
063	84	84	25	20	20	90	84.5	97.5	110.5	775
080	102	102	25	20	20	110	94.5	110	125.5	1430
100	125	125	30	25	25	132	107	120	133	1950
125	155	155	32	25	25	160	126	145	164	1600

INTERMEDIATE ADJUSTABLE HINGE
TOURILLON INTERMEDIAIRE RÉGLABLE
CERNIERA INTERMEDIA REGOLABILE

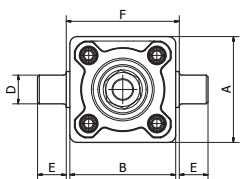
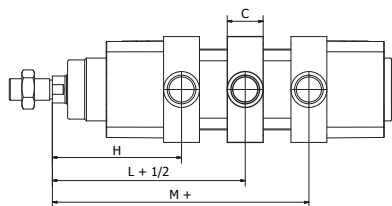
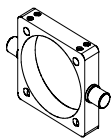

CODE MATERIAL / MATIÈRE / MATERIALE
AR4182 Ø Steel / Acier / Acciaio

Ø	A	B	C	D	E	F	H	L	M	weight (g)
032	46	46	15	12	12	50	61.5	73.5	84.5	250
040	59	59	20	16	16	63	70.5	82.5	94.5	410
050	69	69	20	16	16	75	78	90	102	530
063	84	84	25	20	20	90	84.5	97.5	110.5	775
080	102	102	25	20	20	110	94.5	110	125.5	1430
100	125	125	30	25	25	132	107	120	133	1950
125	155	155	32	25	25	160	126	145	164	1600

SUPPORT FOR INTERMEDIATE HINGE
PALIER POUR TOURILLON
SUPPORTO PER CERNIERA INTERMEDIA

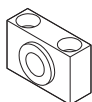

2X

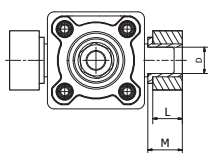
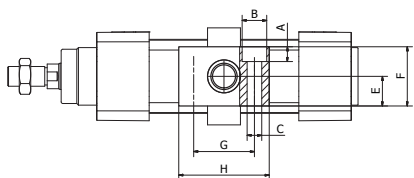

CODE MATERIAL / MATIÈRE / MATERIALE
AR4159 Ø Steel / Acier / Acciaio

Ø	A	B	C	D	E	F	G	H	L	M	weight (g)
032	7	11	6.6	12	15	30	32	46	15	18	100
40-50	9	15	9	16	18	36	36	55	18	21	150
63-80	11	18	11	20	20	40	42	65	20	23	234
100-125	13	20	14	25	25	50	50	75	25	28.5	435

YOKE WITH CLIP
FOURCHE AVEC CLIP
FORCELLA CON CLIP

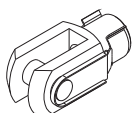

Material: Steel
Matière: Acier
Materiale: Acciaio

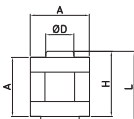
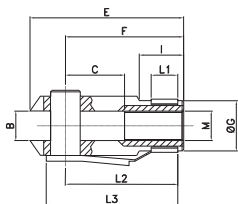

CODE Ø
AR40673 32
AR40674 40
AR40675 50-63
AR40676 80-100
AR40678 125

Ø	A	B	C	D	E	F	G	H	I	M	L	L1	L2	L3
32	20	10	20	10	52	40	18	23	15	M10x1.25	26	10	39	46
40	24	12	24	12	62	48	20	28	18	M12x1.25	32	12	47	55
50-63	32	16	32	16	83	64	26	36	24	M16x1.5	40	14	62	72
80-100	40	20	40	20	105	80	34	44	30	M20x1.5	48	16	72	88
125	55	30	54	30	148	110	48			M27x2	65	38		

ROD ENDS
CHAPE DE TIGE ROTULEE
TESTA A SNODO



Material: Steel
Matière: Acier
Materiale: Acciaio

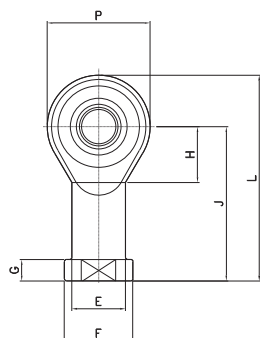
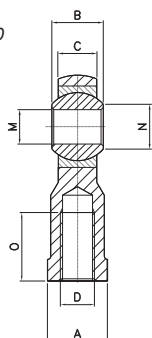

CODE Ø
AR40660 32
AR40662 40
AR40665 50-63
AR40666 80-100
AR40667 125

Ø	A	B	C	D	E	F	G	H	J	L	M	N	O	P
32	17	14	10.5	M10x1.25	15	19	6.5	15	43	57	10	12.9	20	28
40	19	16	12	M12x1.25	17.5	22	6.5	17	50	66	12	15.4	22	32
50-63	22	21	15	M16x1.5	22	27	8	23	64	85	16	19.3	28	42
80-100	30	25	18	M20x1.5	27.5	34	10	27	77	102	20	24.3	33	50
125	41	37	25	M27x2	40	50	15	36	110	145	30	34.8	51	70

SELF-ALIGNING JOINT
CHAPE AUTO-ALIGNANTE
 GIUNTO AUTOALLINEANTE

Material: Steel
Matière: Acier
 Materiale: Acciaio

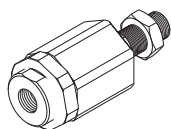
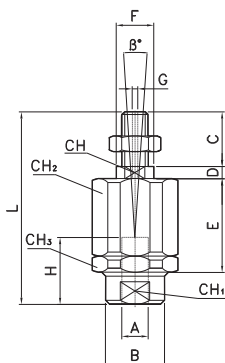

CODE	Ø
AR40689	32
AR40691	40
AR40693	50-63
AR40694	80-100

Ø	A	B	C	D	E	F	G	H	L	CH	CH ₁	CH ₂	CH ₃	B
32	M10x1.25	22	20	5	35	14	2	20	71	12	19	30	32	10
40	M12x1.25	22	24	5	35	14	2	20	75	12	19	30	32	10
50-63	M16x1.5	32	32	8	54	22	2	32	103	20	30	41	45	10
80-100	M20x1.5	32	40	8	54	22	2	40	119	20	30	41	45	10

FLOATING JOINT
GUIDE FLOTTANT
 GIUNTO FLOTTANTE

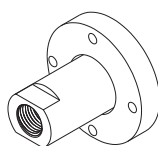
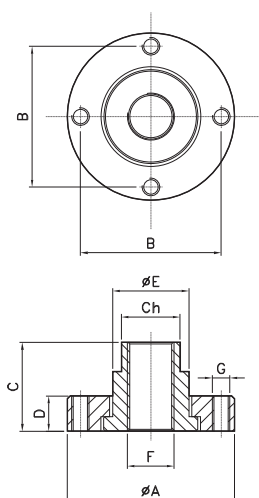

CODE	MATERIAL / MATIÈRE / MATERIALE
KU0017 Ø	Steel / Acier / Acciaio

Ø	ØA	B	C	D	ØE	F	G	CH
16	28.5	22.5	15	6	11	M5	M5	8
20	31.5	25.5	18	7.5	14	M8	M5	12
25	31.5	25.5	18	7.5	14	M10	M5	12
32	38	31	19	11	17	M10	M5	15
40	38	31	19	11	17	M12	M5	15
50-63	57	48	27	12	26	M16	M6	20
80-100	63	54	27	12	32	M20	M6	26

VALVE FIXING PLAQUE FOR CY CYLINDERS
FIXATION POUR VALVE SUR VERIN CY
 PIASTRINA FISSAGGIO VALVOLA SU CILINDRO CY

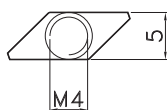

CODE	
AR4213	without screws / sans vis / senza viti
AR4213V	with screws for VY / avec vis pour VY / con viti per VY

NUT FOR ROD
ECROU DE TIGE
 DADO PER STELO

Material: Steel
Matière: Acier
 Materiale: Acciaio

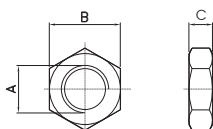

CODE	Ø	A	B	C
DAD10X1.25	32	M10X1.25	17	8
DAD12X1.25	40	M12X1.25	19	6
DAD16X1.5	50-63	M16X1.5	22	6
DAD20X1.5	80-100	M20X1.5	30	8
DAD27X2	125	M27X2	41	12
DAD36X2	160-200	M36X2	55	18

OVAL SWITCH
CAPTEUR OVAL
 SENSORE OVALE

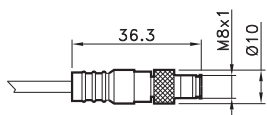
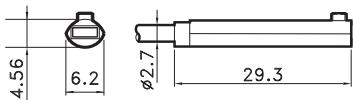

4= black / **noire** / nero
 1= brown / **brun** / marrone
 3= blue / **bleu** / azzurro

CODE

AR4019010	REED (MT.2,5) / REED (MT.2,5) / REED (MT.2,5)
AR4019020	HALL (MT.2,5) / HALL (MT.2,5) / HALL (MT.2,5)
AR4019110	REED + M8 (CM 30) / REED + M8 / REED + M8 (CM 30)
AR4019120	HALL + M8 (CM 30) / HALL + M8 / HALL + M8 (CM 30)

For technical data see page 1.73

Pour les données techniques, voir page 1.73

Per i dati tecnici vedere pag. 1.73

T SWITCH
CAPTEUR EN T
 SENSORE A T

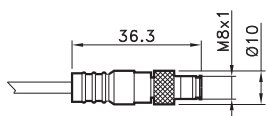
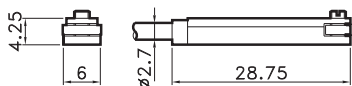

4= black / **noire** / nero
 1= brown / **brun** / marrone
 3= blue / **bleu** / azzurro

CODE

AR4023010	REED (MT.2,5) / REED (MT.2,5) / REED (MT.2,5)
AR4023020	HALL (MT.2,5) / HALL (MT.2,5) / HALL (MT.2,5)
AR4023110	REED + M8 (CM 30) / REED + M8 / REED + M8 (CM 30)
AR4023120	HALL + M8 (CM 30) / HALL + M8 / HALL + M8 (CM 30)

For technical data see page 1.74

Pour les données techniques, voir page 1.74

Per i dati tecnici vedere pag. 1.74

EXTENSION CABLE 2,5 mt
EXTENSION CABLES 2,5 mt
 PROLUNGA CAVO 2,5 mt

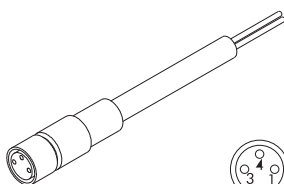

4= black / **noire** / nero
 1= brown / **brun** / marrone
 3= blue / **bleu** / azzurro

CODE

AR4300	WITH M8 2 WIRES / AVEC M8 2 FILS / CON M8 2 FILI
AR4301	WITH M8 3 WIRES / AVEC M8 3 FILS / CON M8 3 FILI

ADAPTOR FOR 'T' SWITCH FOR CG CYLINDERS
ADAPTATEUR DE CAPTEUR EN "T" POUR VERIN SERIE CG
 ADATTATORE SENSORE A 'T' PER CILINDRO SERIE CG

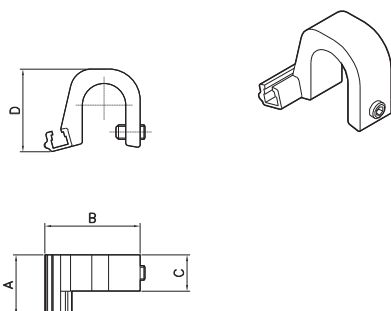

CODE

MATERIAL / MATIÈRE / MATERIALE

AR4200 Ø	Aluminium / Aluminium / Alluminio
-----------------	--

Ø	A	B	C	D
32-40	24	25	12,5	15
50-63	24	34	12,5	24
80-100	24	34	12,5	24